



GAZETTE

In This Issue:

Club Officers	2
President's Message	3
Vice President's Message	4
Rendezvous update	5
Tech Coordinator	6
Tech Session Photos	8
Editors Notes	8
Calendar of Events	9
Other Events	10
Intermarque Picnic	11
Rendezvous	12
Rally in the Valley	14
Brit Fest	16
Regalia	17
Business Ads	18
Classified Ads	19
Membership Form	20

Attention! Attention! - May Highlights !

National MGA Day

May 2nd

Drive Leaving from Square Peg @ 10 A.M.
Through metro area on rarely seen streets
Open to All MG's & Others

&

2009 Spring Kick-off

Hosted by InterMarque Council

May 16

Como Park Picnic Hill & Pavilion Parking Lots
9 A.M. - 2:00 P.M.

May Tech Session - Basic Tuning

Saturday, May 23, 9:00 AM- 11 AM
Quality Coaches, 20 West 38th Street,
Minneapolis

Jeff Schlemmer and Randy Byboth will cover basic valve adjustments, ignition tuning and carburetor tuning. This session is a great precursor to the MG2009 trip and the summer driving season. Discover how to coax the maximum of power and

economy from your MG with simple tools and easy-to-understand techniques. The session will run from 9:00-11:00 AM at Quality Coaches, maybe a bit longer as needed if the folks attending have a lot of questions. For those who want to learn the 'tricks', plan on getting your hands 'dirty'. New members are especially welcome. Call your Tech Coordinator for more info.

We hope to see you there!





Name	Address	E-mail Address
President Richard Wallrich	1860 Roselawn Ave W Falcon Hts MN 55113	chartbus@comcast.net 651-644-0154
Vice President Dawn Williams	951 18 1/2 Ave NE Minneapolis MN 55418	williamsd@emerge-mn.org 612-363-5990
Treasurer & Member Roster Diane Vinar	275 Tiffany Dr Hastings MN 55033	dmvinar@yahoo.com 763-438-6199
Secretary Elena Biessener	10793D Falling Water Ln Woodbury MN 55129	elen2b0916@comcast.net 651-337-0681
Newsletter Editor Ruth Marston	1920 Roselawn Ave W Falcon Hts MN 55113	remarston@comcast.net 651-641-1668
Newsletter Editor, Assistant Bob Anderson	1316 Martha St N Stillwater MN 55082	robtwander1@juno.com 651-439-6876
Regalia Coordinator Cindy O'Brien	5041 Beacon Hill Rd Minnetonka MN 55345	randycindyo@earthlink.net 952-936-9335
Webmaster Jon Masley	3947 Bailey Ridge Draw Woodbury MN 55125	jdmasley@yahoo.com 651-779-8605
Past President Alan Kelsey	15942 Harmony Way Ct Apple Valley MN 55124	alan@rarehome.com 952-891-3452
New Member Coordinator Bill McReaken	10905 27th Ave S Burnsville MN 55387	mgb1969@msn.com 952-890-0102
InterMarque Representative James Pennoyer	4209 Decatur Ave N New Hope MN 55428	mgadriven@yahoo.com
Tech Session Coordinator Dave Braun		dave@dbraun99.com 612-237-0904

The Minnesota MG Group was founded in 1987 and is dedicated to the preservation, restoration, maintenance and enjoyment of the MG cars. MG car ownership is not necessary to be a member of the Minnesota MG Group. Correspondence can be addressed to: Minnesota MG Group - 1860 Roselawn Avenue West, Falcon Heights MN 55113. Visit us on the web at WWW.MMGG.ORG

*The MMGG Gazette welcomes all articles, features and letters. Please submit as text in an E-mail, or attach a pdf if no editing will be required. All articles, features and letters will be subject to editing but all efforts will be made not to change the meaning of the submitted document. **Please submit articles for publication in the Gazette by the 15th of the month to minnesotamggroup@me.com.***



THE LEFT HAND THREAD

MMGG President Richard Wallrich

On vacation and other things at large

Val and I have just wrapped up an eighteen day vacation to Naples Florida. We took our son John and Val's Dad met us down there. Now I don't know how many of you have been to Naples before, but I got the feeling that I was entering another world in a way. After all, how many places can you go where there is a used car lot that deals with ragged used supercars. The cars are outside to face any kind of weather including maybe even a hurricane and the lot caters only to the older Ferrari, Maserati, Lamborghini and any of the one off exotics that you've only seen in magazines. Some of these cars were your fixer uppers too. When was the last time you saw a Lambo Countach with faded yellow paint? Or how about the Aston Martin/Bentley Dealership that had their inventory just sitting out on the street? There wasn't just two Astons out there but about twenty in every color that I imagine they come in. I actually saw more Astons on the road than I saw Corvettes. We only saw two MGB's and one TR4 but they appeared to be daily drivers that were being used for regular daily errands.

You can say what you want about Florida with hanging ballots and other things, but they seem to be able to get things done with their roads in a way that Minnesota can't even begin to figure out. Minneapolis can't get a budget together to cut grass in their parks with 120 administrators in their parks department, but Naples has manicured boulevards and beautiful flowers everywhere. It is very obvious that a decision was made by the city fathers in all of the municipalities down there that they would have nice roads, that they would be planted with nice flowers and that landscaping was going to be the focus in all developments. It's hard to find stores in shopping centers because they are hidden behind so many plantings. You wouldn't see that amount of landscaping at a WalMart store in the Twin Cities. It took me back somewhat, but it was amazing how people down there just couldn't believe how we are unable to elect a senator. I even had a guy come up to me in the Everglades at a small shack where we were going out on an airboat ride come up to me and needle me about our election problems.

As an interesting piece of trivia, Naples and MG's have a very close connection. Baron Collier bought one million acres of land in south Florida in the 1920's. Yes,



I said that right. Now the area is known as Collier County. His sons, Sam and Miles started importing and racing MG's right after the war. They were instrumental in the beginning of Watkins Glen and the United States Gran Prix. The Colliers still have some of the most unbelievable MG race cars that you have ever seen. They house an extensive collection of cars in a large corporate headquarters looking building near the Naples airport. However, it is private and not open to the public. A few of us were lucky to see a few of these cars at Watkins Glen when they brought a couple up there for the 50th anniversary of the Glen a couple of years ago

How about some help

You may or may not be aware of a loosely built association in the Twin Cities called the InterMarque Council. This group brings together all of the sports car clubs together to have, for example, the Intermarque Car Show that's coming up in May. Andy Lindberg really was the founder and overseer of this group and he has been the sole editor, publisher manager, glue-stick and bottle washer of this group that has kept all of the sports car clubs working towards common goals and strengths. Well, Andy just isn't able to do it anymore and Phyllis Galberth has picked up Andy's substantial load. By now, you should be aware of the enormous amount of work that Phyllis Galberth takes on in support of our hobby. She really could use some help in the work of representing all of the clubs. If you have any skills that you;d like to share for the betterment of our hobby, please call Phyllis. Her number is (952) 898-6914.

See you at the InterMarque Car Show at Como Park. Also, Saturday, May 2nd is national drive your MGA day. I'm going to lead a little local tour of street in the Twin Cities that you've probably never driven on. We'll leave from the Square Peg after breakfast. We should be done maybe in time for a little lunch and libation afterwards. You don't have to have a MGA but it helps. Drive what you want.



FROM THE CORNER OF MADAM VICE

Dawn Williams

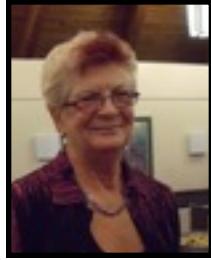

What a great week for convertibles and me with a summer cold. Both my B and my F (in alphabetical order) have been out for a drive this week. It feels wonderful riding close to the ground again in my little cars, sure is a change from my gas guzzling SUV in which I can haul around a houseful of furniture. I hope everyone has their cars out of winter storage and ready for our 209 driving season. There is a lot planned for us so get out your calendar and blackberries and get all the events scheduled.

I got my B home a few weeks ago after spending the winter with Kenny and Diane Merrill. Before I could bring her home I had to empty all my lawn furniture out the car port where she lives during the summer. Before I could do that I had to rake my lawn, then empty the car port, then put the snow blowers in the car port and get the lawn mowers out and into the garage. Then rake out the old weeds and winter debris and presto, I am exhausted but my B is ready to come home. Kenny always has her looking so pretty and clean. She loves staying at his house. Thanks Kenny.

Good turnout for the Kick-off brunch in March with 68 members attending. This is a great way to start off our season. We had hoped to bring up a discussion about providing an updated membership roster to members. We have a question about what information we can share and to whom can we make this information available and we would like some feedback from our members. You can email me with your thoughts and suggestions and I will make sure to share them with the rest of our board members before a final decision is made. My email is dawnbrody@yahoo.com.

The InterMarque Spring Kick-off in Como Park on May 16 from 9 am to 2 p.m. is coming up and should be a great event. This is the first time at this location and the planning committee is excited about the plans for both the exhibition and picnic. They are still looking for volunteers for this event so please contact Phyllis Galberth at deegalberth@yahoo.com if you are able to help out. Remember to bring your picnic lunch, tabletop grills are allowed at the park but you will need to bring your own. Please remember that alcohol is not

allowed and that includes wine and beer. I plan to drive my B and proudly display my new MMGG car emblems. I hope all of you who attend this venue have purchased these but just in case they will be on sale that day with the MG Regalia. Check it out.

There are two rides planned for May. One is for the National MGA day on May 2. We will meet at the Square Peg at 8 am for breakfast and leave by 10. This will All A's, B's, F's, GT's, GTB's and all the rest of the alphabet as well are welcome. be a drive on local city streets, some of which you may never have traveled. Come on and join us.

The other is a ride on May 30. Again we will meet at 8 am at the Square Peg and head out by 10. We will stop for lunch while we are out so plan for a nice ride in the country with maybe some great sights, a flea market or an ice cream shop along the way.

Have you sent in your reservations for Rendezvous 2009 in Ashland, Wisconsin yet? You will save \$15.00 if you register before May 15 so get out the form and send it in. Rendezvous is always a wonderful event with a lot to do and this year certainly looks like that is going to be true. Tom Moerke has been promoting this event and encouraging everyone to come out. It's always part of the fun to get a group together and drive up caravan style. Let me know if you want to start out on Tuesday June 9 and make an excursion out of the trip to our destination. I would be willing to plan the trip with the help of my friends (I don't even know how to get there so I really need some help on this one). We sure want to make sure the MMGG club is well represented.

We have several people working on scheduling some good tech sessions so make sure you check these out. In April the glass repairing session at Iburg's was a great idea and there are others schedule for May and June. The first thing I head for is the calendar of events. I don't want to miss anything because before you know it cold weather will be upon us. We need to take advantage of all the summer driving weather we have.

If any of you would like to host an event this summer just let me know. We'll get your event into the newsletter and presto, some friends to travel with.

See you on the road

Safety Fast



This Just In - Rendezvous Update
from our WI Correspondent - T. Moerke

The Rendezvous Planning Committee has firmed up plans for the June 11-14 Rendezvous in Ashland, WI.

People can start picking up their registration material at the AmericInn Motel in Ashland thursday afternoon. We have rented the Northern Great Lakes Visitor Center for Thursday evening from from 5-8 p.m. for a private Hospitality Reception for all the guests coming to Rendezvous. In addition to beer, wine, soft drinks , and fancy goodies there will be information available on the activities of the weekend. You can sign up for the tour you want to go on and find out all about the car show and the autocross. And you can greet old friends you haven't seen in a year. Friday morning there are two tours.

Wayne Soderbeck and Jan Huston have put together a 165 mile long tour that will stop at a waterfall and at least 2 wineries and a diner in Delta. They say they have discovered a road to surpass all others for being the ideal sports car road. Even better then the long fabled Co. O in western Wi.. Their tour will leave the AmericInn at 9:00 AM....

Tom and June Moerke will conduct a guided tour of Bayfield and Madeline Island. Their tour will leave the Americinn at 9:30 and will follow around the shores of Chequamagon Bay to Bayfield and then on a ferry boat to Lapoint, the village on Madeline. It should be noted that a round trip for your car is \$24.00 and \$5.75 for each person on the ferry. More details on both these tours will be available Thursday night at the reception.

Friday night we are on our own to find a restaurant of our liking. The three towns of Ashland, Washburn and Bayfield have a great variety ranging from the Golden Arches to really fancy places with matching prices. Rumors of wild parties on Friday night are probably not true, I think. There will be roasting marshmallows and s'mores on the beach . We have heard of a couple who are bringing a case of bubbly. Don't forget splashing in the waterpark at the motel.

Saturday morning will find us polishing up our cars for the car show. The City of Ashland is blocking off 2 and a half blocks right downtown for our car show. Dale Martin has produced the great hand made trophies and he and Tom Politiski will run the car show.

In the afternoon Tom Hazen will conduct the Autocross at the Ashland Airport. Maybe the same car will win its class at the car show and be top dog at the

autocross. Maybe. Saturday night will be the awards banquet with our very own Andy Lindberg as the MC.

Kevin Clemens, the noted author,editor of European Car Magazine, vintage car racer and really long distance rallyist will be the speaker. Oh, there will be a cash bar before and during the banquet.

Sunday morning we will have breakfast, say our goodbyes and start thinking about the **20th Rendezvous in Thunder Bay in 2010!**

Taillight Replacement Option.

Steve Kolseth (1979 MGB) has noticed that the MG tail lights are not very visible, and is addressing this problem with a possible solution - an LED taillight replacement set.

<http://www.youtube.com/watch?v=TsZS65-ROI8>

For information about the light and an introductory discount to all British Car Club Members - Call or e-mail for details.

<http://www.classicautoleds.com>.

or

Steve Kolseth - 541-619-8335

steve@classicautoleds.com

MMGG Technical Advisors

Dave Braun – Tech Coordinator

dave@dbraun99.com 612/237-0904

The following people have expressed a willingness to answer questions and offer advice about the topics below.

Take them up on their offer.

Bodywork – Open

Electrical - Jeff Schlemmer 612/804-5543

jeff@advancedistributors.com

MGA - Brian McCullough 651/462-0145

brian@bmcautos.com

MGB - Randy Byboth 952/936-9335

randycindyo@earthlink.net

Midgets - Brian McCullough 651/462-0145

brian@bmcautos.com

Triple-M - Lew Palmer 651/436-7401

T-types - Bob Figenskau 952/935-7909



FROM THE GARAGE

Dave Braun,
Tech Coordinator



Spark Plugs

Last month we covered valve lash adjustment. If you tried this at home, and your car seems to have more get-up and go, then you did it right! This month we are going to talk about spark plugs and wires. Half the fun of driving LBCs (little british sport cars) is that, except for the members of the North American MGF register, everything is right there under the bonnet, and everything under the bonnet will respond to tuning with simple tools.

I can't tell you how many times I've had people tell me that their MG was suddenly running poorly. The engine was no longer smooth, was missing like it was starving for fuel, or lacked top-end power and response. In cases like this, people seem to gravitate to the carburetors. STOP! Put the screwdriver down and slowly back away from the MG. I would like to suggest a method that will prove to be as satisfying as working on the carburetors, have a higher potential for success, and leave you more time for DRIVING your pride and joy. This process has a specific order: Breathing, Fire, Fuel.

Breathing is making sure that big ol' air pump of an engine can get all the air it needs at the right moments and use that air to create power. So we first do a compression test to see if something major, like a burnt valve or bad rings are causing the problem. Even if the car doesn't pass this test, it still may respond to basic tuning. Then we do a valve adjustment to assure that the engine is gulping in its air in concert with all the other combustion processes. Air flowing into the engine at the wrong moments is like running a marathon with a paper bag over your head. You can make it work, but it won't be pleasant.

Fire is the process of adding spark at timed events in the engine cycle to get the engine to expel the air it is breathing, creating the power stroke. Fire consists of the ignition coil, distributor, spark

plug wires and spark plugs. Coils last a long time. You can make them last longer by simply keeping the ignition off when you aren't running the engine. Coils are generally 12 volt (three ohm) or six volt (1-1/2 ohm) and you can measure for this with a digital multi meter with the points closed. The 12 volt coil uses a special resistance wire to feed the coil normally, bringing it down to six volts, and a separate wire to bring it up to 12 volts for starting. The six volt coil just works a bit harder to start the car. Disconnecting and holding a plug wire with an insulated pliers a quarter inch from the engine while cranking it over will demonstrate if the coil is doing its job. Now we can check out the wires and the spark plugs.

Give a gentle tug on each of rubber boots connecting the fat wires to the spark plugs and to the distributor (don't pull one the wires!). They should pop right off. You may want to mark them first, one through four, from the front of the engine. Early caps don't have distributor boots, the wires are fixed with screws from inside the cap. Mark the distributor cap where one attaches. From there, counter-clockwise, will be three, four and two. Early cars will have solid copper wires encased in a rubber sheath. The resistance in the earlier wires will be zero if they are unbroken and in good shape. The ends of the copper wires should be over the copper washers. Some people like to solder the wires to the washers, I usually just go for bending them in a star pattern.

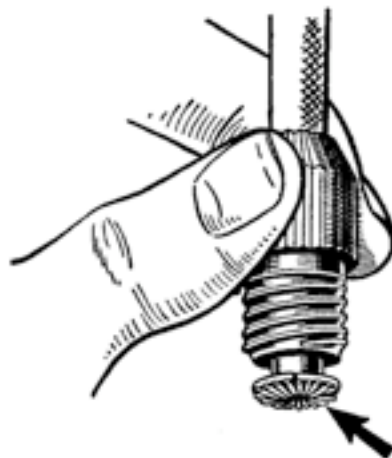

0825HW

Fig. B.6
The correct method of fitting a high-tension cable to the ignition coil terminal nut

Later cars will have carbon conductors as original equipment ignition wires and in the majority of stock replacement wires. This style of ignition wire generally provides good suppression for both RFI (radio frequency interference) and EMI (electromagnetic interference). The conductor usually consists of a substrate of fiberglass and/or Kevlar over which high-resistance conductive latex or silicone is coated. They function by reducing spark current (by resistance) to provide suppression, a job it does well while the conductor lasts. You can check the resistance of carbon conductor wire but the value will vary according to the length and type. Just make sure all the resistance readings are similar to each other. This type of conductor also quickly fails (burns out) if a high-powered aftermarket ignition system is used.

Regardless of wire type inspect the outer case for breaks, cracks or carbon arcing. To make new wires, buy a four cylinder set of the appropriate type, and cut them down to the length of the old wires, placing the conductors and rubber boots on the wires as needed. Replace them in their proper positions, remembering the center coil wire too, and you are all set.

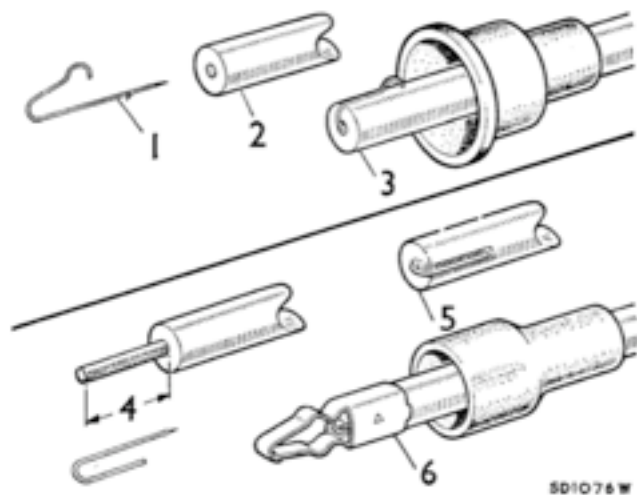

Fig. B.8

The correct assembly method for later-type suppressed high tension cables

- | <i>Coil lead</i> | <i>Plug leads</i> |
|--|--|
| 1. Fish-hook connector. | 4. Insulation removed for 1/8 in. (12.7 mm.). |
| 2. Flush cable end. | 5. Inner cord folded onto cable, staple pushed into the centre of the cord as far as possible. |
| 3. Assembly of fish-hook and lead cover. | 6. Cord and staple must make a good contact with body of connector. |

Spark plugs are removed with a spark plug socket that has some internal padding to protect the insulator. It is still possible to break a spark plug, so be gentle. The normal look of a good plug is tan to brown without traces of carbon build up or oily deposits. The insulator should be crack free and have no evidence of arcing. The gap is checked according to the tune up information for your engine, but for most MGs it is about .025 for an early car and .035 for a later one. Using a feeler gauge with gapping levers, practice gapping an old plug if you aren't sure of your skills. You can clean your plugs, but be careful of scratching off any of the sealant on the insulator, and make sure the edges of the plug electrodes are nice and square. Given all that, replacing the plugs is easier and will offer more peace of mind. Auto parts stores will have the correct plug for your MG. After checking the gap, add a dab of never seize to the plug threads and carefully thread the plugs into the head. This is no time to cross a thread! The spark plug thread should be free enough to thread in almost all the way. When you hit the compressible gasket, go one more quarter turn or so, you'll feel the gasket compress. Replace the wires by pressing the boot down until you feel a slight 'click' and you're done! Since the conductivity of the carbon conductors break down and spark plugs wear, this simple procedure should be done every 10,000 to 12,000 miles. If you wait until your car is 'acting' up, you'll be amazed at how effective replacing plugs and wires can be! Or, be like me and do it as routine maintenance. We'll continue 'Fire' next month by adjusting the points and the timing.

Safety Fast!

June Preview

Installing Gas Lift Struts for Your Boot & Bonnet
Thursday, June 25
Dave Braun, Hastings



April Tech Session @ Iburg's by Phyliss Galberth & Larry Henle



Editors' Notes

Well there almost wasn't room for these ramblin's (aka Editors' Note) but apparently, we need more volunteer photographers. There apparently were no cameras present at the Gourmet Gathering, and I'm sure I would have printed photos from the Healey Spring Fling if any MGs showed up ! But again, no photographers present. So you are stuck with filling space.

My review of the latest MMGG membership list our numbers are down by many members. Apparently many have still not paid their 2009 membership dues. In April we still had 150+ members receiving the Gazette by Email and 18 by Postal. We are still around 18 Postal, but down to 130 by Email. Get those payments in to Diane Vinar ASAP.

The DRIVE scheduled for 30 May starts with Breakfast at the Square Peg at 8 a.m., the drive starts at 10 a.m., and it will be about a 2 hour drive to a winery. Lunch around 2 p.m. with those dining ordering from the restaurant menu. Dick & Dawn need an email by 25 May to alert the Restaurant.

I hope to have 72B on the road by then, but somehow by to-do list doubled over the winter! How's that happen!



2009 Calendar of Events (Revised 30 Apr 09)

DATE	EVENTS	HOSTS or CONTACTS
May 2, Sat	Nat'l MGA Day - Meet @ Square Peg 8 am for breakfast and leave by 10.	Dick Wallrich will lead a drive for All A's, B's, F's, Y's, GT's, GTB's - on St. Paul streets !
May 23, Sat	Tech Session - Tuning MG the basics	Jeff Schlemmer
May 30, Sat	Drive - to an undected winery	Dick & Val Wallrich (& Dawn Williams)
Jun 11-14	Rendezvous 2009	glauser@presenter.com
Jun 20, Sat	Night at the Drive-In	Elena & Dick Biessener
Jun 25, Thu	Tech Session - Tuning MG the basics	Dave Braun
Jul 4, Sat	Chetek Car Show	Steve & Diane Rindt
Jul 11, Sat	Garden Party	Bosworths & Schneiders
Jul 16-19	Road American, Elkhart Lake, WI	
Jul 18, Sat	Picnic	Phyllis & Keith Galberths
Jul 22, Wed	Tech Session - Fitting an oil cooler	Bruce Anderson
Jul 25, Sat	Grand Round Tour	Dawn Williams
Aug TDB	Tech Session - Driving Tech	Brian McCullough
Aug 6-9	Rally in the Valley	Steve & Diane Rindt
Aug 15, Sat	Brit Fest @ Ellingson's	Jim & Cindy Pennoyer's
Sep 12, Sat	Wings & Wheels	D Braun, D Vinar & Tom & Barb Belongia
Sep 19, Sat	Drive to Arboretum	Bill & Lorna McReaken
Sep 26, Sat	Pig Roast	Jon & Haidi Masley
Oct 3, Sat	Fish & Chips	Tom & Barb Belongia
Oct 17, Sat	Fall Colour Tour	Steve & Kim Rixen
Oct 24, Sat	Tech Session, Winterize your car	Keith Galberth & Jim Pennoyer
Oct 31, Sat	Halloween Party	Bob & Lorie Jensen
Nov TBD	Tech Session - Suspension safety, etc	Quality Coach - tentative
Nov 7, Sat	MMGG Annual Meeting	
Nov 14, Sat	MG Girls Craft Day	
Dec TBD	MMGG Christmas Event	Val Wallrich & Dawn Williams
Dec 31, Thu	New Years Eve Party	
Jan 16, 2010	Annual Holiday Party	Merrill's, Berguist's & Biessener's



Calendar of Other Car Club Events

Saturday Morning British Breakfast at the Square Peg Diner

Open to all lovers of British cars. Proprietor Phil Vanner, British car owner, welcomes you. New expanded dining room too - from 8:30 a.m. to 11:00 a.m. (most people get there early). After breakfast we linger in the parking lot, weather permitting, to "show off" our cars at: **2021 East Hennepin Avenue, Minneapolis**

East Ender's Saturday Morning Breakfast

A group of MG'ers have started a semi-monthly East Enders Breakfast group. For those MG (and any other) enthusiasts that want breakfast a little later and not drive to Minneapolis. Join us on the 1st and 3rd Saturdays each month, 9 AM at: **Sail Away Café, 1321 St. Croix Trail, Afton, Mn. North of County Road 18 and St. Croix Trail.**

Saturday Morning - All Year Round - MG Girls

We meet the second Saturday of each month at the **Square Peg Diner.**

Date	Event	Host or Contact
May 9	Scottish Fair - Dakota Co. Fair Grounds Farmington, MN Gates Open at 8 a.m.	Jim Harris @ JHarris@MNScottishFair.org http://www.mnscottishfair.org
May 9	Healey Hillclimb VIII - Afton Alps Rec. Area 7:00 AM Check in opens - 8:30 AM Drivers Mtg.	Tom Hazen myliberty@comcast.net forum.mnautox.com/forums/showthread.php?t=10664
May 15-17	Carlisle Import & Kit Car Show	
May 15-17	Spring Races @ Elkhart	jeffj@centuryrefining.com
May 16	InterMarque Banquet & Car Show Como Park Picnic Hill - Pavilion Parking Lots	Phyliss Galberth @ deegalberth@yahoo.com Aaron Courteau @ aaroncourteau@gmail.com
Jun 6, 2009	Mid-Iowa Brit/Euro Car Classic - Des Moines Iowa	www.midiowacarclassic.com
Jun 11-14	Vintage Sports Car Rendezvous AmericInn Ashland WI	Tom Moerke tcmoerke@presenter.com MN Austin-Healey Club glaiser@presenter.com
Jun 20	Amery Speed Run V	Tom Hazen myliberty@comcast.net www.mmgg.org/scheduled_events.htm
Jun 24-28	MG 2009 NAMGBR @ Breckenridge CO	N. American MGB Register mg2009.com
Jun 28	InterMarque Picnic	Cherokee Park, St Paul
Jul 13-17	NAMGAR GT-34	N. American MGA Register, Hot Springs, AR www.mgcars.org.uk/namgar/shtml/events.shtml
Jul 26	InterMarque Picnic	
Aug 22	Amery Speed Run VI	Tom Hazen myliberty@comcast.net www.mmgg.org/scheduled_events.htm
Aug 30	InterMarque Picnic	Cherokee Park, St Paul



**2009
SPRING
KICK-OFF
COMO PARK**

Hosted by:



Event Co-Chairs: Phyllis Galberth and Aaron Courteau

Event Sponsors:

- Minnesota Austin Healey Club :: Premier Sponsor ::
- Jaguar Club of Minnesota :: Premier Sponsor ::
- Citroen Car Club of Minnesota
- Lotus Owners of the North
- Lotus Eaters
- Metropolitans from Minnesota
- Minnesota MG Group
- Minnesota MGT Register
- Minnesota Triumphs
- Transportation Artists and Authors Guild
- Vintage Sports Car Racing

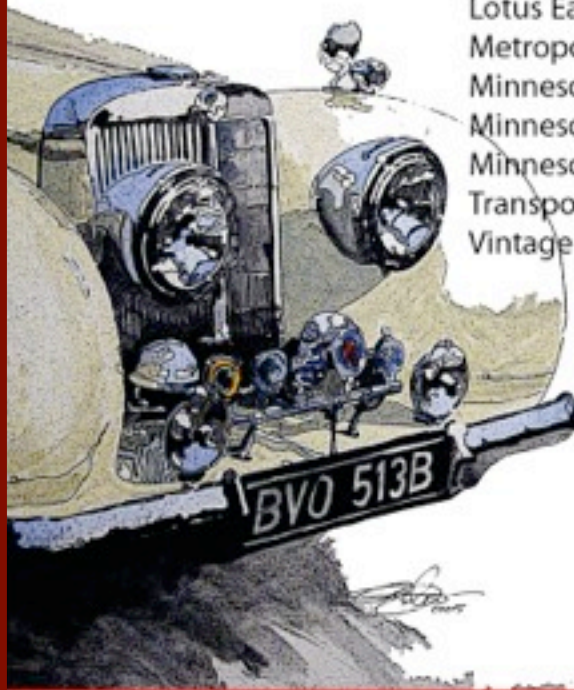

**SATURDAY
MAY 16 2009
9:00AM - 2:00PM**

MOTORCAR PLACEMENT STARTS 8:00 A.M.

**COMO PARK PICNIC HILL
AND PAVILION PARKING LOTS
1360 LEXINGTON PARKWAY N
ST. PAUL MINNESOTA**

The Motorcar Exhibition:

Open to all VINTAGE FOREIGN motorcars, motorcycles, scooters vintage racers **1984 and older**. Exhibitors are requested to PLEASE pre-register for the Motorcar Exhibition by e-mail to, Phyllis Galberth: deegalberth@yahoo.com **BEFORE May 8, 2009**

Exhibitors Social Gathering:

Please bring your own PICNIC and enjoy a spring afternoon with vintage foreign motoring enthusiasts on Como Park Picnic Hill.

Special Attractions:

Local motoring club displays, artists and authors Exhibit from the Transportation Artists and Authors Guild, special photo opportunities for the exhibitors and more.....In addition there are terrific activities / sights in Como Park (Zoo, Conservatory, Hamm Memorial Waterfalls).

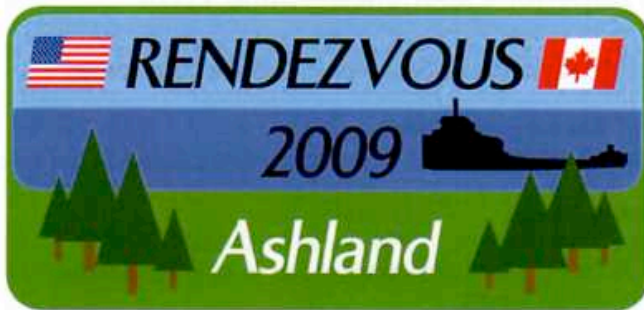

19TH ANNUAL
VINTAGE SPORTS CARS CELEBRATION
ASHLAND, WISCONSIN

“A SUPERIOR EXPERIENCE”

JUNE 11 -14

Thursday – Registration: 3-7 p.m. Hospitality Reception: 5-8 p.m.
Friday -- Registration 8 a.m.-Noon, Driving tours to Bayfield & Madeline Island areas, Golfing
Saturday -- AutoCross, Car Show, Walking Tour & Awards Banquet
Sunday -- Breakfast & Goodbyes

Name _____ Spouse/Guest _____
(PRINT LEGIBLY first and last name/names as they should appear on badges)

Children Attending _____
(Include names & ages of each child)

Street _____ City _____

State/Province/PostalCode _____ Club _____

E-mail address _____ Phone _____
(Include e-mail address if you want a confirmation of registration – none will be sent otherwise.)

Vehicle/s to be registered _____
(Year) (Make) (Model)

(Year) (Make) (Model)

Registration Fee: \$50.00 After May 15: \$65.00 (All fees in U.S. dollars) \$ _____
(Registration includes one vehicle, two adults, one child under 18 & one free T/shirt)
Each additional person: \$5.00 x _____ \$ _____
Each additional vehicle: \$5.00 x _____ \$ _____
Free shirt size _____ 2nd shirt _____ 3rd shirt _____ Added shirts: _____ x \$10.00 \$ _____
(T-Shirt Sizes: Small, Medium, Large, XL) (For XXL & XXXL – Cost is \$13.00)
Awards Banquet tickets: \$25.00/adult x _____ \$ _____
\$20.00/child under 13 x _____ \$ _____
Total \$ _____

Make checks to Minnesota Austin-Healey Club (U.S. funds) and send with completed form to:
Greg Lauser, W12349 694th Ave., Prescott, Wis. 54021
Registration questions to: glauser@presenter.com
Cancellations before 5/15/05 are subject to a \$10.00 fee. No refunds after May 15.

I want to play golf with a Rendezvous 2009 group _____
(A Rendezvous Golf organizer will contact you with details & greens fees information)

Contact AmericInn directly for headquarters hotel room reservations in Ashland, Wis. @
1-715-682-9950 or www.AmericInn.com.



Welcome to Rendezvous 2009 – A Superior Experience – June 11-14

Where: The pristine shores of Chequamegon Bay on Lake Superior in Ashland, Wisconsin

Ashland Accommodations:

Identify yourself as part of Healey Rendezvous 2009 for Special Room Rates (plus taxes) listed below.

- Headquarters hotel: **AmericInn Motel & Suites**
 3009 Lake Shore Drive East Phone: 715-682-9950
 80 rooms at \$109.00/night (on reservations made by May 11) include complimentary breakfast + pool.
- If AmericInn is full: **Lake Superior Lodge (Best Western)**
 30600 Highway 2 West Phone: 715-682-5235
 20 rooms at \$109.00/night (good through May 11).
 Restaurant: Explorer's Point / Blue Heron Bar
- Hotel Chequamegon**
 101 Lake Shore Drive West Phone: 715-682-9095
 20 rooms at \$109.00/night (good through May 23)
 include complimentary breakfast + pool
 Restaurant: Molly Cooper's Eating & Drinking Establishment
 Molly's Fish Fry – Friday - \$10.95 to \$14.95
- Ashland Super 8 Motel**
 1610 Lake Shore Drive West Phone: 715-682-9377
 10 rooms at special rates (good through May 11) of:
 One Bed Room - \$53.95 Thursday; \$62.95 Friday & Saturday.
 Two Bed Room - \$80.95 Thursday; \$89.95 Friday & Saturday.

My wife likes all the car-related activities planned, but what will I do?

- . Visit the Northern Great Lakes Visitor Center, www.NGVC.org
- . Visit the Ashland Historical Museum, 715-682-4911
- . Visit the Washburn Historical Museum, 715-373-5591
- . Visit the Big Top Chautauqua, www.bigtop.org
- . Take the ferry to Madeline Island, www.madferry.com
- . Rent a moped on Madeline Island, www.madelineisland.com
- . Visit the Madeline Island Historical Museum, 715-747-2415
- . Cruise & explore the Apostle Islands, www.apostleislands.com
- . Visit, shop & dine in Bayfield, www.bayfield.org
- . Visit the Bayfield Heritage Museum, 715-779-3272
- . Rent a kayak & explore Lake Superior from shops in Bayfield
- . Visit Cornucopia, www.cornucopiawisconsin.org
- . Visit the Oulu Glass Studio, www.ouluerglass.com
- . Gamble at Isle Vista Casino, www.redcliff.org
- . Play 18 holes of golf (A Rendezvous Golf coordinator will contact you if register to do so)





Rally in the Valley 2009

August 6th thru 9th (2009)

What is the definition of "Rally"?

(A gathering of people intended to arouse enthusiasm!)

"Rally in the Valley" is a European InterMarque sports car event.

Sponsored by: The Minnesota MG Group.

Hosted by: Steve and Diane Rindt

2009 Theme, "Those Were The Days"

All New Location:

The Eau Claire Travel and Business Center
Sleep Inn and Suites / 29 Pines
5872 33rd Ave - Eau Claire, WI 54703

Beautiful Wisconsin Roads for the scenic drives:

These Rallies are not for the serious rallier. They are fun with easy directions & questions, "spouse friendly"



Schedule:

- Thursday (6th)– Registration & Natter – N – Noggin.
- Friday (7th) – Magic Carpet Ride Rally.
- Friday Evening (7th) – Italian Banquet & Live music.
- Saturday (8th) - Country Tour, Car Show & Funkhanna.
- Saturday Evening (8th) - Awards Dinner/Ceremony.
- Sunday (9th)- Farewell breakfast.

For questions please contact Diane Rindt (715) 832-8316 or email drindt5953@hotmail.com

**Make your reservations at: Sleep Inn & Suites Conference Center / (715) 874-2900.
Ask for the "Rally in the Valley 2009" special rate. (\$79.99 a night for 2 Queen or 1 King)**



Rally in the Valley 2009

August 6th, 7th and 8th at Sleep Inn & Suites - Eau Claire, WI

Name:			
Address:			
Email:			
Vehicle/s to Register:	Year:	Make:	Model:
	Year:	Make:	Model:
Friday & Saturday Breakfast Buffet: (Cost includes BOTH days.) Cost includes tip and tax.			
Adult (\$15.00) x Qty		= Total	
Friday Lunch: (Magic Carpet Ride Rally) Cost includes tip and tax.			
Adult (\$11.00) x Qty		= Total	
Friday Night: (Italian Banquet) Cost includes tip and tax.			
Adult (\$18.00) x Qty		= Total	
Saturday Night: ("Those Were The Days" Awards Banquet) Cost includes tip and tax.			
Adult (\$26.00) x Qty		= Total	
Rally in the Valley T-Shirts: ("Those Were The Days")		(Circle Size)	
Men's (\$15.00) x Qty	= Total	Size: S, M, L, XL, (2XL add \$2.00)	
Rally in the Valley T-Shirts: ("Those Were The Days")		(Circle Size)	
Women's (\$15.00) x Qty	= Total	Size: S, M, L, XL, (2XL add \$2.00)	
Rally in the Valley Registration Fee:			
(Before June 30, 2009) \$40.00 per / couple Total			
(After June 30 th) \$45.00 per / couple Total			
EVENT TOTAL			
Make Check Payable to Diane Rindt.			
Send check & Registration Form to:			
Rally in the Valley - 4271 North Shore Drive, Eau Claire, WI 54703			
(Register Before June 30, 2009) Confirmation of registration will be through your email address only.			
No refunds after July 12, 2009.			

Rally in the Valley 2009 – August 6th thru 9th – Eau Claire, Wisconsin

Make your reservations at: Sleep Inn & Suites Conference Center / (715) 874-2900.
5872 33rd Ave - Eau Claire, WI 54703

Ask for "Rally in the Valley 2009" special rate. (\$79.99 a night for 2 Queen or 1 King)

For questions, contact Diane Rindt at (715-832-8316) or drindt5953@hotmail.com



Car show and Swap meet

August 15th 2009

The Minnesota MG Group presents:
The annual Brit Feszt
All British Car, Bike Show & Swap-meet at Ellingson's Car Museum 20950 Rogers Dr. Rogers MN 55374

9:00am to 1:00pm
Peoples choice balloting from 9:00 to 12:00.
Trophies at 1:00



The Car show is
Free to the Public
Tour the museum for \$5.00



Show your vehicle for \$5

Swap meet spaces

\$10 per space

Please **no** FOR SALE signs on any vehicles.

The areas largest
All British Car & Bike Show and swap meet! Now in our **12th** year!



Ellingson's Car Museum
20950 Rogers Dr.
Rogers, MN 55374-9191
Corner of Hwy 101 and I-94 in Rogers
Contact: Minnesota MG Group,
Jim Pennoyer (763)536-5472





MINNESOTA MG REGALIA

Shirts in **various styles** and **colors** with custom-embroidered Minnesota MG Logos are now available for ordering. Items can be picked up at the next Event or shipped directly to the address you specify. A

Shipping & Handling fee of \$5.00 will be added.

Add an additional fee of \$3.00 if you want your name stitched on your purchase.

To place orders contact: Cindy O'Brien randycindyo@earthlink.net



MG Girl Tank Top (\$12.50 each) MG Girl Patches (\$7.00 each) MMGG Tank Tops (\$12.50 each)



MMGG Sweatshirts (\$27.00 each)

MMGG POLO SHIRTS (\$24.00 each)



(\$30.00 each)



(\$35.00 each)

MMGG Denim Shirts (Short and Long Sleeve)



(\$15.00 each)



Short Sleeve T-Shirts MG Patches (\$7.00 each)

There are many more options of clothing not shown here when ordering MMGG Regalia. Ask Cindy if you want to see the various styles of:

Jackets (Summer/Fall and Winter) - Hats (Base Ball, Stocking Caps, Visors) - T-Shirts Short/Long Sleeve, Tank Tops - Denim, Polo, Dress Shirts - Sweat Shirts Plain/Hooded, Pullover/Zipper



Business Ads



Jeff Schlemmer
jeff@advanceddistributors.com

Rebuild and Recurve Specialists

612-804-5543
1149 Quincy Street
Shakopee, MN 55379
www.advanceddistributors.com



MIDWEST MOTOR SPORTS, INC.

728 8th Avenue South
Sauk Rapids, MN 56379
(320) 251-0676
SPORTS CAR SPECIALISTS
www.sportscarguys.com

BMC British Automobile
BMCAutos.com

6810 225th Ave NE, Stacy, MN 55079

- Full Restorations, Drivers to Concourse
- Repair and Maintenance
- Vehicle Alterations and Upgrades
- Motor and Driveline Conversions
- Online Conversion Store

Proprietor: Brian McCullough
651-462-0145 Brian@BMCAutos.com

Quality Coaches, Inc.
20 West 38th St. (38th & Nicollet)
Minneapolis, MN. 55409
Ph. 612-824-4155, Fax 612-824-4460 Email:
ValW@quality-coaches.com
MOSS Distributor
STOCKING PARTS TO KEEP YOUR MG-
TRIUMPH-AUSTIN HEALY RUNNING.
**30 YEARS SERVICE FOR BRITISH CARS,
FOREIGN & DOMESTIC REPAIR.**



Eau Claire British Car

Quality service and restoration
715-456-1174
www.eauclairebritishcar.com
British and Foreign Classic Cars
Steve Rindt
4271 North Shore Drive, Eau Claire WI 54703



CARS WANTED

Very Serious Buyer for:
Jaguar, XK-XKE, MG-"T" series, MGA
Triumph, TR-2-3-4-250
Mercedes 190-220-230-250-280 SL
All open cars Porsche 356-911-914
Austin Healey, Riley, Alfa-Romeo, Singer
1964-1967 Ford Mustang, Model T, A

Entire Collections Possible
ANY CONDITION-ANY LOCATION
Generous Finder's Fee. WILL PAY THE MOST !

1930's-1960's
Buying Restored Gas Pumps
Also other interesting cars
European and American made

STEVE'S BRITISH CONNECTION USA
(630) 553-9023 email sbcinc@aol.com



Jeffrey
BODY SHOP

COLORMAN / BRITISH AUTO
4108 20th Ave South Mpls, MN.55407
JeffJamesPaint@yahoo.com 612-724-5267



For Sale or Wanted & Miscellaneous

Minnesota MG Group members' ads will run free for three months, unless you tell the editor to drop them earlier or run them longer. The month/year the ad was placed is in italics below the ad. Commercial Ads as follows: Business Card—\$10.00/issue; 1/4 page—\$20.00/issue; 1/2 page—\$30.00/issue; full page—N/A. All commercial ads must run a minimum of 6 months and must be paid in advance. Send to Ruth Marston, 1920 Roselawn Ave W, Falcon Heights, MN 55113 or remarston@comcast.net. Make checks payable to the MMGG. If you are a member, please indicate this when placing the ad or notice and provide a full name so information can be verified. Our apologies for any. Don't shoot the messenger!

For Sale: MGBGT Driver's side quarter panel, NOS. Call Todd Wyatt (320) 980-2010 (*Mar 09*)

For Sale: 1969 MGB GT - complete driveline for sale. Coming from a partial restoration and V6 driveline conversion. Nice running engine, good set of HS4 carbs, completely restored MGB Overdrive. The system as is will come with the carbs, starter, alternator, motor, distributor, Overdrive gearbox and driveshaft - will consider splitting. Maintenance records available. Installation into your MGB available if desired. Also available is an MGB 3 main short block that was partially rebuilt and stored a number of years ago. Please email: brian@bmcautos.com or telephone 651.462.0145. (March 09)

For Sale: 2002 MINI Cooper - 43,800 miles Red with Black roof and slate black interior. Every option, including Navigation system, leather interior, cold weather package (heated washer fluid, heated seats, heated mirrors), sunroof, stability control, 16" wheels, fog lights, xenon headlights, sport suspension, aero package ground effects. Has extra bumper set front and rear, fitted MINI car cover & much more. Always stored in winter in heated garage. New tires. Always properly maintained. If you're thinking of getting a MINI-this is the car to buy - \$12,000.00 firm. Contact Dick Wallrich for info on add'l options. 651-644-0154. (May 09)

New and Refurbished MGB Parts For Sale:

MGB Windshield - MGB roadster windshield with **New Chrome plating** on the frame, new Moss Triplex tinted glass and new seals. All assembled - \$950.00

MGB Windshield - MGB Roadster windshield with refurbished frame with new Moss tinted glass and new seals. All assembled - \$480.00

MGB Windshield Frame - MGB Roadster windshield frame-Refurbished and assembled to confirm proper fit - \$210.00

MG Midget Windshield Frame - MG Midget windshield frame with **New Chrome Plating** and new post retainers - \$550.00

MGB-GT Windshield Wiper Arms - Black - \$ 20.00 ea.

MGB Wood Veneer Trim Set - center console and glove box door - MGB 72'-76' - Cherry or Walnut Wood - \$110.00, Ash or Oak Wood \$95.00

MGB Seat Set - Professionally installed new custom upholstery over refurbished frames, new foam and new seat webbing - plus new Teardrop style head rests. Black with Red piping. Complete and ready for installation - \$1125.00

MGB Seat Set - Professionally installed upholstery over refurbished frames and new foam and seat webbing. With "D" style head rests. Complete and ready for installation. Autumn Leaf color vinyl - \$685.00

MGB Dash - Refurbished dash for 72'-76' MGB. New total dash face installed over a completely refurbished dash base. Ready to install - \$445.00

MG 14" Wheels - Original Rostyle MG wheels. Refurbished and restored to original color and then clear coated. Set of 5 - \$400.00

MGB Rear Bumper - New rear bumper, 70'-74' MGB style, complete with all new brackets and new over riders/bumper guards - \$200.00

MGB Brake Pipe Set - New copper-nickel set for 68'- early 74' MGB - \$ 65.00

Engine Hoist - 2 ton folding engine hoist - including an engine leveler - \$ 95.00

Please Contact Roger Olson at 763-420-8159 or Cell 612-963-1127 - www.rljolson@embarqmail.com.

Quality Coaches, Inc.

Call Mark @ Quality Coach Inc. on his cell phone at 612-306-0044

1952 MGTD. Coming Soon - still under wraps & awaiting arrival. \$??,???

1960 Austin Healey 3000 MK I BT7. Red with black interior, chrome wire wheels, tonneau, older soft top. Has overdrive. \$20,000 invested in recent restoration, selling for only \$30,000

1962 Midget, MK I Green. Mag Wheels with a 1275 engine, 5 Speed Trans. This is a distressed sale. \$5,500

1979 MGB White with wire wheels. Needs a new owner soon. \$4,895.

1979 MGB Orange with black interior. Rose style wheels. 85k miles. \$5,500 OBO

MMGG will not sell your information or share it with third parties for marketing or other purposes.

The MMGG *Gazette* welcomes all articles, features and letters. Please submit as text documents. All articles, features and letters will be subject to editing but all efforts will be made not to change the meaning of the submitted document. Please submit articles for publication in the *Gazette* by the 15th of the month to minnesotamggroup@me.com or remarston@comcast.net



Minnesota MG Group Membership Form

The Minnesota MG Group was founded in 1987 and is dedicated to the preservation, restoration, maintenance and enjoyment of all MG cars. MG car ownership is not necessary to be a member of the Minnesota MG Group.

Membership is \$35.00 with a \$5.00 discount if paid before the spring Kick Off Brunch - March 28, 2009. The membership year runs from January 1st to December 31st. New members joining after August 31st of any given year shall be granted membership for the remainder of that year and the next year as well.

Use this form to join, renew or change your membership. Please complete this form and include a check for \$35 (or \$30 if paying before mid-March).

MMGG will not sell your information or share it with third parties for marketing or other purposes.

Mail to: Minnesota MG Group c/o Diane Vinar, 275 Tiffany Drive, Hastings, MN 55033 dmvinar@yahoo.com

New Renewal Changes (Circle one)

Name _____ Spouse/partner/significant other _____

Street Address _____ City, State, & Zip _____

Telephone w/area code: (_____) _____ - _____ Email Address _____

MG's) Owned: _____

Minnesota MG Group
c/o Diane Vinar
275 Tiffany Drive
Hastings, MN 55033

