



# GAZETTE

## In This Issue:

Club Officers	2
President's Message	3
Vice President's Message	4
Tech Coordinator	5
Tech Session Photos	7
& Humor	
InterMarque Photos	8
Miscellaneous Page	9
Editors' Notes	9
Calendar of Events	10
Other Events	11
Rendezvous	12
Rally in the Valley	14
Brit Fest	16
Regalia	17
Business Ads	18
Classified Ads	19
Membership Form	20

## Attention ! Attention ! RENDEZVOUS 2009

**“ A Superior Experience “  
19th Annual Vintage Sports  
Cars Celebration**

**Ashland, Wisconsin  
11-14 June**

**A Weekend of Tours, Adventure,  
Fun & Frivolity !**

### June Tech Session

**25 Jun - Thur - 6:30 PM - 10 PM,  
“Installing Gas Lift Struts for Your  
Boot and Bonnet”**

**275 Tiffany Drive, Hastings, MN**

**Dave Braun and Diane Vinar** will end years of painful agony incurred by banging our heads on the boot and bonnet of Diane's 1970 MGB by installing Gas Lift Struts. The parts will be pre-painted and ready to install, and we will go over the

important points to assure a good fit and maximum open clearance. We will also show you how to safely drill the holes without going through the pretty side of your paint. If you want to participate in the project on your own car, order your Gas Lift Struts from Moss Motors now and bring them along. We'll get you started. Bring a dish to share for dinner, and something to grill if you like. We will have plates, utensils, pop and beer on hand.





Name	Address	E-mail Address
President Richard Wallrich	1860 Roselawn Ave W Falcon Hts MN 55113	<a href="mailto:chartbus@comcast.net">chartbus@comcast.net</a> 651-644-0154
Vice President Dawn Williams	951 18 1/2 Ave NE Minneapolis MN 55418	<a href="mailto:williamsd@emerge-mn.org">williamsd@emerge-mn.org</a> 612-363-5990
Treasurer & Member Roster Diane Vinar	275 Tiffany Dr Hastings MN 55033	<a href="mailto:dmvinar@yahoo.com">dmvinar@yahoo.com</a> 763-438-6199
Secretary Elena Biessener	10793D Falling Water Ln Woodbury MN 55129	<a href="mailto:elen2b0916@comcast.net">elen2b0916@comcast.net</a> 651-337-0681
Newsletter Editor Ruth Marston	1920 Roselawn Ave W Falcon Hts MN 55113	<a href="mailto:remarston@comcast.net">remarston@comcast.net</a> 651-641-1668
Newsletter Editor, Assistant Bob Anderson	1316 Martha St N Stillwater MN 55082	<a href="mailto:robtwander1@juno.com">robtwander1@juno.com</a> 651-439-6876
Regalia Coordinator Cindy O'Brien	5041 Beacon Hill Rd Minnetonka MN 55345	<a href="mailto:randycindyo@earthlink.net">randycindyo@earthlink.net</a> 952-936-9335
Webmaster Jon Masley	3947 Bailey Ridge Draw Woodbury MN 55125	<a href="mailto:jdmasley@yahoo.com">jdmasley@yahoo.com</a> 651-779-8605
Past President Alan Kelsey	15942 Harmony Way Ct Apple Valley MN 55124	<a href="mailto:alan@rarehome.com">alan@rarehome.com</a> 952-891-3452
New Member Coordinator Bill McReaken	10905 27th Ave S Burnsville MN 55387	<a href="mailto:mgb1969@msn.com">mgb1969@msn.com</a> 952-890-0102
InterMarque Representative James Pennoyer	4209 Decatur Ave N New Hope MN 55428	<a href="mailto:mgadriven@yahoo.com">mgadriven@yahoo.com</a>
Tech Session Coordinator Dave Braun		<a href="mailto:dave@dbraun99.com">dave@dbraun99.com</a> 612-237-0904

The Minnesota MG Group was founded in 1987 and is dedicated to the preservation, restoration, maintenance and enjoyment of the MG cars. MG car ownership is not necessary to be a member of the Minnesota MG Group. Correspondence can be addressed to: Minnesota MG Group - 1860 Roselawn Avenue West, Falcon Heights MN 55113. Visit us on the web at [WWW.MMGG.ORG](http://WWW.MMGG.ORG)

*The MMGG Gazette welcomes all articles, features and letters. Please submit as text in an E-mail, or attach a pdf if no editing will be required. All articles, features and letters will be subject to editing but all efforts will be made not to change the meaning of the submitted document. **Please submit articles for publication in the Gazette by the 15th of the month to [minnesotamggroup@me.com](mailto:minnesotamggroup@me.com).***



## THE LEFT HAND THREAD

MMGG President, Richard Wallrich

### Random Thoughts

We have a big month of motoring activities, with Rendezvous, the NAMGBR convention and local drives and car shows to attend. Take time to get your car out to something and to promote the hobby as much as you can. Also, welcome also to all of the new members we have this month.

Jon Masley is now officially retired from 3M as of May 29th. This means that he is now free to wash and wax your car for you. Just leave it out in the driveway when you go to work and Jon will happily come over to clean it up for you during the day.

As a final tidbit, there is a new book out about the beginning of the sports car hobby in the USA. It's titled, *The Gentleman's Club*, and it was written by Pete Hylton. Pete is historian for the Sports Car Club of America (SCCA). The book chronicles the beginning of sports cars in America and road racing in the early days. It's a fascinating read especially if you've ever wondered how all of this got started? Well, it really did have pretty much a finite start in the USA. I have some books for the club. See me at one of the events if you're interested in a copy. They are \$25.00.

### Caravan to Rendezvous in Ashland, WI

For those of you who believe what your mother told you about safety in numbers, we will have a caravan that will be going up to Rendezvous on Thursday, June 11th. We will meet at the Perkins restaurant in Forest Lake at 8:00 AM for breakfast. The Perkins is located just off of Interstate 35 at the Broadway exit. The address is 1155 Broadway for those setting those GPS machines. We will be taking the less travelled roads to Ashland, but we'll make some fun stops along the way. (Gotta at least make a stop at the fudge shop!) This caravan is geared to those that have the lower cubic inch machines and that may require a more leisurely pace in which to pursue their motoring hobby.



## END of the ROAD

University Motors will cease fulltime business on Wednesday, July 1st, 2009, after 34+ years of service to the MG community. When our Governess promised in her 2006 State of the State Address that "In five years, you're going to be blown away by the strength and diversity of Michigan's transformed economy," little did we imagine that it would be our own business that would be demolished in the ensuing economic storm.

We have ceased taking appointments and will use the month of June to complete the work in the shop. We will continue to receive bench work. In late October we will have an auction of parts, tools, and MG memorabilia. Books, DVDs, and technical publications will be forthcoming.

All good things must come to an end. It's been a simply wonderful run!

*Found this on the web site for University Motors.*



Possibly the worst thing that anybody has done to an MGA - suggestion is this should not allowed to own a sports car!



## FROM THE CORNER OF MADAM VICE

Dawn Williams

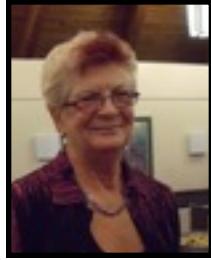

Have any of you ever driven down University Avenue on Friday or Saturday nights in the summer? Have you ever gone past Porky's drive-in restaurant? You know the one with Porky Pig's head on the sign. Then you have seen the wonderful display of muscle cars, cars popular in the 50's and 60's that have been restored and beautifully maintained. On warm summer Friday and Saturday nights people line up on University with lawn chairs to watch the parade of vintage muscle cars go by and pull into the lot to park for the evening. This has been an event for 30 plus years. In addition to the camaraderie amongst the owners of those gorgeous cars, this event has provided a fun evening of entertainment for car enthusiasts, both young and old alike.

Several years ago, the owners of the Porky's on University bought a lot on Central Avenue NE and 19<sup>th</sup> St. in Northeast Minneapolis with the intent of building a new Porky's restaurant on this site. After many struggles they were granted the building permit and today we see the smaller version of Porky's with yet a smaller parking lot. But the lot should be just right for smaller cars, like our MG's.

I have talked with the owners Nora and Tryg Truelson and they would be delighted to host our car club at the Central Avenue location. Here is my idea. On June 26, a Friday night from 6-9 p.m. we will hold an MG car show in the parking lot of the Porky's restaurant on 19<sup>th</sup> and Central Avenue NE. For those of you who know where I live, it is just around the corner from my house. If there are a lot of MG's that night, we can also park on Central Avenue and I think we can accommodate about 30 cars. The Northeast parade is Tuesday of that week and I will prepare a flyer, showing some of our cars lined up, that will tell area residents about this new event to distribute during the parade. If we are well received, we could make this a regular event. There is another drive-in under construction further up on 44<sup>th</sup> and Central NE. The Sonic drive-in could very well be another site for us to visit and have a parade between the two locations on Central. The building is supposed to be ready and open the end of June so who knows where this could lead.

Please let me know if you are interested in coming on June 26 so I can make sure we have room for everyone. This location has been struggling to get off the ground and many of us are interested in helping them be successful so your support would be appreciated. Porky's has great food. They are not your typical fast food restaurant and if you choose to eat when you come to the car show, I think you will be pleased with their menu and quality. They have both counter space, indoor and outdoor tables or you can eat in your car. You can either call me at 612-363-5990 or email me at [williamsd@emerge-mn.org](mailto:williamsd@emerge-mn.org) to save you a parking place. I hope to hear from many of you. Let's give my neighborhood a show.

On June 11-14 many of us will be traveling to Ashland, Wisconsin for Rendezvous 2009. I hope you will be joining us. Several of us will be heading up on Wednesday in a caravan. If you would like to join us please let me know. You know my email address, right? Last month I said I would lead a caravan but I didn't know where it was or how to get there. Within a few days I received a Wisconsin map from Tom Moerke. What service. Now I know how to get there. Tom and June have been working hard to get good participation to Rendezvous this year. There are several tours planned and I am excited. I have never been to Madeline Island and it sounds interesting. The Moerkes are leading that tour and I am confident that it will be full of great stops, good food and wonderful shopping. You still have time to get your reservations in so pull the form out of the Gazette and come on along. June is also planning a special treat for everyone but it's a secret. You need to come to Rendezvous to experience the "special treat".

June 24-28 is the North American MGB Register in Breckenridge, Colorado. What a trip that will be. I know several of our members are going out for that event. What a wonderful trip that will be. This is a great time to hook up with MG enthusiasts from other parts of the country. Some that we met in Gatlinburg, Tennessee. As I remember our MMGG President and First Lady, Dick and Val Wallrich are going out for this event. Sounds like another caravan is in order.

Another tech session is on the schedule for June and then before you know it July will be here. A lot of driving events are planned for this year so please check it out in this month's Gazette but make sure you have your calendar or blackberry handy because you will want to attend a lot of the events.

Till then, see you on the road.  
Safety Fast!



## FROM THE GARAGE

Dave Braun,  
Tech Coordinator



### Points & Timing

This month it is time for the other part of the 'fire' portion of "Breathing, Fire, Fuel"- setting the points and timing. We've already tested our compression, set our valve lash, replaced our spark plugs and wires on our 'not quite running right' LBC. I hope you don't get tired of the admonition, but really, check the carburetors on a poorly running MG last!

Those of you who have succumbed to the electronic points world can skip ahead to timing, but if you want to know what you are missing, or be of use when a fellow driver's engine won't run, stay with us here.

I cut my teeth on automotive points in the seventies (yeah, I know, some of you were driving with them way before that!) we serviced them yearly as part of our tune-ups. Over time I had forgotten the nuances. Almost 20 years ago, I was driving to the Gathering Of the Faithful (GOF) in Duluth with Rudy and Karl. The three of us were cruising along on a rain swept two lane in our T-Types. Karl in a TC, myself in a TD, and Rudy in his TF. Every time we stopped my engine would sputter and die. The cranking to get it going again was excessive. I chalked it up to poor fuel or too much vapor pressure in the transverse tube of the SU carbs. The cranking resulted in a new battery in North Branch, and by the time we pulled off on Lake Drive in Duluth, the car would no longer run even at higher RPMs. Karl pushed me the last half mile to the GOF (Embarrassing!). Dave Zyp, a noted Ohio MG specialist, pounced on my TD before it was even completely into the hotel parking lot, tore off my distributor cap and with a match book cover adjusted the point gap. The car was trouble free the rest of the weekend, in fact it was trouble free until I took it apart for restoration. Mind you, I had already owned the TD for 5 years, but I had never done this kind of maintenance. It was then that I vowed to learn all I could about maintaining my own car, and relying on experts only when special tools were needed.

Points are found in the distributor. They have a little cam follower and open and close as the cam on the distributor shaft rotates. (If you have electronic points,

they are simply a hall effect magnetic pick-up trigger.) So it is easy to see that they can be made to open and close in concert with the need for spark plug firing. Their purpose is to interrupt the current flowing in the primary circuit of the ignition coil, collapsing the current which induces a high voltage in the secondary winding of the coil. This causes a very large voltage to appear at the coil output for a short period - something like 20 thousand volts, enough to arc across the electrodes of the spark plug we adjusted last month.

To compensate for wear of the points and the arcing that may take place across them, there has to be a condenser up stream, but we won't worry about that now. Condensers are usually not a problem, but if your car is misfiring or backfiring, it may be the condenser. The fact is that points do wear and need replacement and/or adjustment from time to time. The duration the points are closed is called the dwell, when the coil is waiting to discharge its voltage (dwelling) until the time the points open. The points are also attached to the advancing mechanism of the distributor so they can fire the spark plugs earlier as the engine speed increases to compensate for the speed of the flame front of the combustion air charge.

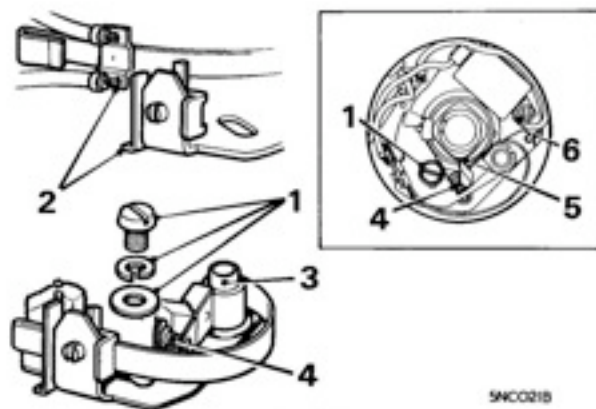

Fig. B.10

Removing a contact breaker set—Lucas 45D4.

- |   |  |
|---|--|
| 1. Securing screw.                            | 5. Heel of contact point on highest point of any one of the cam lobes. |
| 2. Terminal plate and contact breaker spring. | 6. Slot in contact breaker plate for adjusting gap with screwdriver.   |
| 3. Pivot post.                                |  |
| 4. Contact breaker points.                    |  |

Take the cap off the top of the distributor and lay it aside with the wires still attached. Remove the rotor (the thing that points the spark at the right spark plug wire) and drop a bit of oil (not too much) down the shaft to lubricate the advance mechanism. Noting the wires, washers, electrically isolating spacers, and the nuts involved, remove the old points and inspect them. If there are pitted you can file the points flat, or you can



throw the old points into your spares bag and install a new set. To reinstall, simply reverse the disassembly portion, putting a bit of grease on the distributor cam to let the cam follower slide along better. Rotate the engine until the cam follower is on one of the cam apexes (high points). With the points mounted slightly loose, play with a blade of a screwdriver against the mounting plate and note how you can change the gap. Once you figure this out, slip in a feeler gauge and carefully adjust the points until the .014 thousands gauge will slip in, and the .016 gauge won't. This will give you about 60 degrees of dwell (points closed time) and 30 degrees of points open time. A Dwell-Tach is an inexpensive electronic device that you can use to see both your engine RPM and your points setting. Practice a few times and you will get the points set very accurately, with or without a Dwell-Tach. Note that the more you 'open' your points, the less your points will be closed, and the fewer degrees of 'dwell' you will have. Once you are satisfied, lightly lubricate any moving parts, and put your distributor cap back in place.

To adjust your timing, you can use the static method, or use a simple strobe timing light. Static timing involves a 12 volt lamp on test wires between a ground and the contact point terminal on the distributor. As long as the points are closed, the lamp is out because the current flows through the points, not the lamp. With the engine at your timing reference point for firing number one spark plug (usually 5 to 10 degrees before top dead center) set aside the distributor cap as before, loosen the distributor lock bolt and twist the rotor clockwise to fully retard the ignition, and turn on your ignition switch. Then rotate the distributor counter clockwise until the lamp goes out, and back again clockwise until the lamp just lights up, as the points have just opened and the current is now flowing through the test lamp. Lock down the distributor and replace the cap. Road testing will reveal the presence of ignition pinging, and the idea is to run with as much advance as possible without pinging under load.

Strobe timing is done with the engine running, vacuum in place and connected, and a timing light aimed at the timing marks... which on early MGBs you will find under the engine. (See why I covered static timing first?). Hook up the timing light per the instructions, but most require the battery as a power source. The brown wires on your fuse box come directly from the battery, so you can hook up there and then pick a good ground. The timing light probably has an inductive pick-up, so just attach that portion to the front cylinder plug wire. With a dab of white, highlight the marks you are most interested in for timing at idle. You then simply loosen the distributor,

start the engine and rotate the distributor until the strobe is triggered on those marks. Again, driving the car will be necessary to assure the timing is correct.

Next month... Carburetors!

Safety Fast!

### July Tech Session Preview

Fitting an Oil Cooler

Do You Want to, and How to Care for It

Wednesday 22 July

{time & location TBD}

**Bruce Anderson**

Contact Bruce Anderson or Dave Braun if you would like to assist on this session.



### MMGG Technical Advisors

**Dave Braun – Tech Coordinator**

[dave@dbraun99.com](mailto:dave@dbraun99.com) 612/237-0904

The following people have expressed a willingness to answer questions and offer advice about the topics below.

Take them up on their offer.

**Bodywork** – Open

**Electrical** - Jeff Schlemmer 612/804-5543

[jeff@advancedistributors.com](mailto:jeff@advancedistributors.com)

**MGA** - Brian McCullough 651/462-0145

[brian@bmcautos.com](mailto:brian@bmcautos.com)

**MGB** - Randy Byboth 952/936-9335

[randycindyo@earthlink.net](mailto:randycindyo@earthlink.net)

**Midgets** - Brian McCullough 651/462-0145

[brian@bmcautos.com](mailto:brian@bmcautos.com)

**Triple-M** - Lew Palmer 651/436-7401

**T-types** - Bob Figenskau 952/935-7909



May Tech Session @ Quality Coach

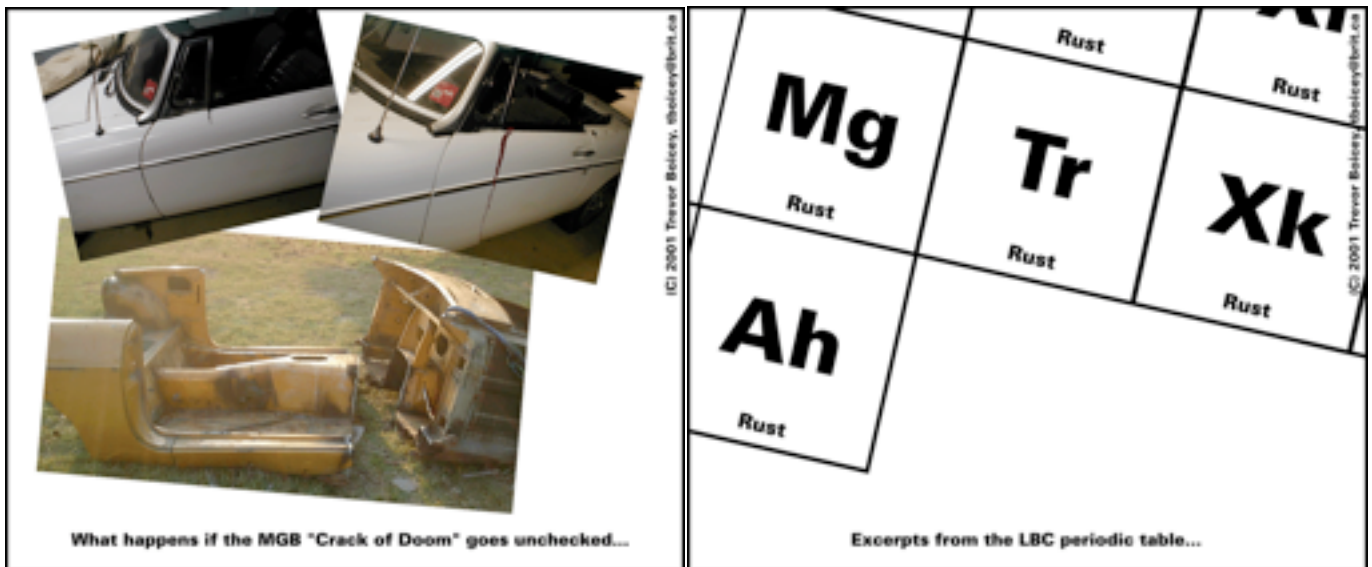

Humor Courtesy of : <http://www.boicey.com/comics.html>



*InterMarque Spring Kick-off - 16 May 09 @ Como Park - St. Paul, MN*



**Safety Fast!**

*Photos by Diane Rindt & Bob (Andy) Anderson - contributors are always welcome*



**THE MISCELLANEOUS PAGE - THINGS THAT JUST SLIPPED IN !*****MMGG Night at the Drive-In!!***

IF THE WEATHER IS GOOD we will be having a Minnesota MG Night at the Cottage View Drive-in on Saturday, June 20. The drive in is located on Highway 61 at Innovation - their "official address is 9338 East Point Douglas Drive in Cottage Grove.

Don't know what will be playing yet, but the shows start at dusk. They open about an hour before dusk so let's get there early so we can all park together and have a pot luck picnic dinner. Bring a dish to pass and your own utensils. Grills are not allowed.

Cost is \$7.50 for adults - \$3.00 for children. Sound for the movie is provided through your car radio, so if the radio on your MG does not work plan to bring a good portable radio.



At Scottish Fair - Cold out here!

***Taillight Replacement Option-***

Steve Kolseth (1979 MGB) has noticed that the MG tail lights are not very visible, and is addressing this problem with a possible solution - an LED taillight replacement set.

<http://www.youtube.com/watch?v=TsZS65-ROI8>

For information about the light and an introductory discount to all British Car Club Members - Call or e-mail for details.

<http://www.classicautoleds.com>.

or

Steve Kolseth - 541-619-8335

[steve@classicautoleds.com](mailto:steve@classicautoleds.com)

***For Sale******1952 MG-TD***

A RARE OPPORTUNITY TO BUY AND DRIVE AN INSTANT TROPHY WINNER.

The unfortunate passing of Dean Baarda forces this sale --- \$27,900.

Driven less than 1000 miles since being professionally restored in 1999.

A restoration with no compromise in originality and careful attention to drivability. Finished in Cream with all new Green leather upholstery and top of the line tan stayfast weather equipment. Top quality chrome plating and easy highway touring with 4.3 to 1 differential gearing.

The car is located in Grinnell, Iowa. For more information and pictures - call Brent Baarda at 312-474-2432 or for more information on the restoration, call Bob Figenskau at 952-935-7909.

***Editors' Notes***

Summer is sure upon us, but then the next day Spring is upon us too. So it is no wonder I'm still in the Spring mode of getting my 72B ready for summer!

I'm one of those that waits for Spring weather to return to my garage to start repairs for Summer driving. As I've mentioned before - with my being relatively new to MG ownership I still get surprised that my 6 things-to-do last Fall increased to 10 things-to-do over the Winter.

So far this year (Spring) I've taken on the removal of the heater box to replace the heater core, as well as all those lovely little seals and gaskets that enable that box to work. I'm about done with the heater system, just in time for Summer. And - Yes! It takes 4 hands, 4 shoulders, as well as a hammer and a 2x4 to get it back in. I just love that rubber block at the base of the heater !

Next on the agenda is leaf springs. I got my butt off the floor last year by replacing the supports under the seats, but now I need to get the car itself off the ground. I can't drive around Rosedale without those speed bumps bottoming me out.

Come July I just might be "on the road again" - Of course I realize at the end of Fall, I'll still have 10 things-to-do, which will somehow grow to 13 things by Winter's End.

**Andy**



## 2009 Calendar of Events (Revised 30 May 09)

DATE	EVENTS	HOSTS or CONTACTS
Jun 11-14	Rendezvous 2009-Ashland, Wisc.	<a href="mailto:glauser@pressenter.com">glauser@pressenter.com</a>
Jun 20, Sat	Night at the Drive-In-Cottage Grove	Elena & Dick Biessener
Jun 25, Thu	Tech Session - Tuning MG the basics	Dave Braun
Jun 26, Fri	Car Show @ Porky's on Central Ave	6-9 PM - Dawn Williams (see VP Article)
Jul 4, Sat	Chetek Car Show	Steve & Diane Rindt
Jul 11, Sat	Garden Party	Bosworths & Schneiders
Jul 16-19	Road American, Elkhart Lake, WI	
Jul 18, Sat	Picnic	Phyllis & Keith Galberths
Jul 22, Wed	Tech Session - Fitting an oil cooler	Bruce Anderson
Jul 25, Sat	Grand Round Tour	Dawn Williams
Aug TDB	Tech Session - Driving Tech	Brian McCullough
Aug 6-9	Rally in the Valley	Steve & Diane Rindt
Aug 15, Sat	Brit Fest @ Ellingson's	Jim & Cindy Pennoyer's
Sep 12, Sat	Wings & Wheels	D Braun, D Vinar & Tom & Barb Belongia
Sep 19, Sat	Drive to Arboretum	Bill & Lorna McReaken
Sep 26, Sat	Pig Roast	Jon & Haidi Masley
Oct 3, Sat	Fish & Chips	Tom & Barb Belongia
Oct 17, Sat	Fall Colour Tour	Steve & Kim Rixen
Oct 24, Sat	Tech Session, Winterize your car	Keith Galberth & Jim Pennoyer
Oct 31, Sat	Halloween Party	Bob & Lorie Jensen
Nov TBD	Tech Session - Suspension safety, etc	Quality Coach - tentative
Nov 7, Sat	MMGG Annual Meeting	
Nov 14, Sat	MG Girls Craft Day	
Dec TBD	MMGG Christmas Event	Val Wallrich & Dawn Williams
Dec 31, Thu	New Years Eve Party	
Jan 16, 2010	Annual Holiday Party	Merrill's, Bergquist's & Biessener's



## Calendar of Events - Other Car Clubs

### **Saturday Morning British Breakfast at the Square Peg Diner**

Open to all lovers of British cars. Proprietor Phil Vanner, British car owner, welcomes you. New expanded dining room too - from 8:30 a.m. to 11:00 a.m. (most people get there early). After breakfast we linger in the parking lot, weather permitting, to "show off" our cars at: **2021 East Hennepin Avenue, Minneapolis**

### **East Ender's Saturday Morning Breakfast**

A group of MG'ers have started a semi-monthly East Enders Breakfast group. For those MG (and any other) enthusiasts that want breakfast a little later and not drive to Minneapolis. Join us on the 1st and 3rd Saturdays each month, 9 AM at: **Sail Away Café, 1321 St. Croix Trail, Afton, Mn. North of County Road 18 and St. Croix Trail.**

### **Saturday Morning - All Year Round - MG Girls**

We meet the second Saturday of each month at the **Square Peg Diner.**

Date	Event	Host or Contact
Jun 6, 2009	Mid-Iowa Brit/Euro Car Classic - Des Moines Iowa	<a href="http://www.midiowacarclassic.com">www.midiowacarclassic.com</a>
Jun 11-14	Vintage Sports Car Rendezvous 2009 AmericInn - Ashland WI	Tom Moerke <a href="mailto:tcmoerke@presenter.com">tcmoerke@presenter.com</a> MN Austin-Healey Club <a href="mailto:glouser@presenter.com">glouser@presenter.com</a>
Jun 20	Amery Speed Run V	Tom Hazen <a href="mailto:myliberty@comcast.net">myliberty@comcast.net</a> <a href="http://www.mmgg.org/scheduled_events.htm">www.mmgg.org/scheduled_events.htm</a>
Jun 24-28	MG 2009 NAMGBR @ Breckenridge CO	N. American MGB Register <a href="http://mg2009.com">mg2009.com</a>
Jun 28	InterMarque Picnic	Cherokee Park, St Paul
Jul 13-17	NAMGAR GT-34	N. American MGA Register, Hot Springs, AR <a href="http://www.mgcars.org.uk/namgar/shtml/events.shtml">www.mgcars.org.uk/namgar/shtml/events.shtml</a>
Jul 26	InterMarque Picnic	
Aug 22	Amery Speed Run VI	Tom Hazen <a href="mailto:myliberty@comcast.net">myliberty@comcast.net</a> <a href="http://www.mmgg.org/scheduled_events.htm">www.mmgg.org/scheduled_events.htm</a>
Aug 30	InterMarque Picnic	Cherokee Park, St Paul

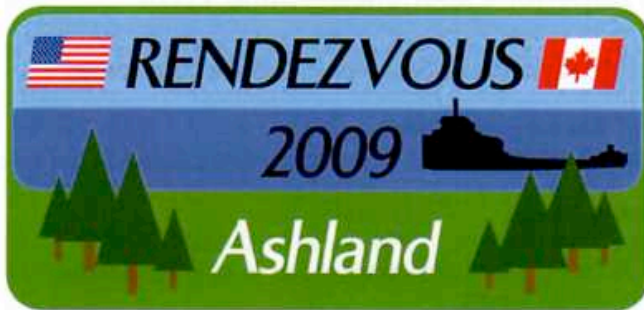

19<sup>TH</sup> ANNUAL  
VINTAGE SPORTS CARS CELEBRATION  
ASHLAND, WISCONSIN

“A SUPERIOR EXPERIENCE”

JUNE 11 - 14

Thursday – Registration: 3-7 p.m. Hospitality Reception: 5-8 p.m.  
Friday -- Registration 8 a.m.-Noon, Driving tours to Bayfield & Madeline Island areas, Golfing  
Saturday -- AutoCross, Car Show, Walking Tour & Awards Banquet  
Sunday -- Breakfast & Goodbyes

Name \_\_\_\_\_ Spouse/Guest \_\_\_\_\_  
(PRINT LEGIBLY first and last name/names as they should appear on badges)

Children Attending \_\_\_\_\_  
(Include names & ages of each child)

Street \_\_\_\_\_ City \_\_\_\_\_

State/Province/PostalCode \_\_\_\_\_ Club \_\_\_\_\_

E-mail address \_\_\_\_\_ Phone \_\_\_\_\_  
(Include e-mail address if you want a confirmation of registration – none will be sent otherwise.)

Vehicle/s to be registered \_\_\_\_\_  
(Year) (Make) (Model)  
\_\_\_\_\_  
(Year) (Make) (Model)

Registration Fee: \$50.00 After May 15: \$65.00 (All fees in U.S. dollars) \$ \_\_\_\_\_  
(Registration includes one vehicle, two adults, one child under 18 & one free T/shirt)  
Each additional person: \$5.00 x \_\_\_\_\_ \$ \_\_\_\_\_  
Each additional vehicle: \$5.00 x \_\_\_\_\_ \$ \_\_\_\_\_  
Free shirt size \_\_\_\_\_ 2<sup>nd</sup> shirt \_\_\_\_\_ 3<sup>rd</sup> shirt \_\_\_\_\_ Added shirts: \_\_\_\_\_ x \$10.00 \$ \_\_\_\_\_  
(T-Shirt Sizes: Small, Medium, Large, XL) (For XXL & XXXL – Cost is \$13.00)  
Awards Banquet tickets: \$25.00/adult x \_\_\_\_\_ \$ \_\_\_\_\_  
\$20.00/child under 13 x \_\_\_\_\_ \$ \_\_\_\_\_  
Total \$ \_\_\_\_\_

Make checks to Minnesota Austin-Healey Club (U.S. funds) and send with completed form to:  
Greg Lauser, W12349 694<sup>th</sup> Ave., Prescott, Wis. 54021  
Registration questions to: [glouser@presenter.com](mailto:glouser@presenter.com)  
Cancellations before 5/15/05 are subject to a \$10.00 fee. No refunds after May 15.

I want to play golf with a Rendezvous 2009 group \_\_\_\_\_  
(A Rendezvous Golf organizer will contact you with details & greens fees information)

Contact AmericInn directly for headquarters hotel room reservations in Ashland, Wis. @  
1-715-682-9950 or [www.AmericInn.com](http://www.AmericInn.com).



## Welcome to Rendezvous 2009 – A Superior Experience – June 11-14

Where: The pristine shores of Chequamegon Bay on Lake Superior in Ashland, Wisconsin

### Ashland Accommodations:

Identify yourself as part of Healey Rendezvous 2009 for Special Room Rates (plus taxes) listed below.

- Headquarters hotel: **AmericInn Motel & Suites**  
 3009 Lake Shore Drive East Phone: 715-682-9950  
 80 rooms at \$109.00/night (on reservations made by May 11) include complimentary breakfast + pool.
- If AmericInn is full: **Lake Superior Lodge (Best Western)**  
 30600 Highway 2 West Phone: 715-682-5235  
 20 rooms at \$109.00/night (good through May 11).  
 Restaurant: Explorer's Point / Blue Heron Bar
- Hotel Chequamegon**  
 101 Lake Shore Drive West Phone: 715-682-9095  
 20 rooms at \$109.00/night (good through May 23)  
 include complimentary breakfast + pool  
 Restaurant: Molly Cooper's Eating & Drinking Establishment  
 Molly's Fish Fry – Friday - \$10.95 to \$14.95
- Ashland Super 8 Motel**  
 1610 Lake Shore Drive West Phone: 715-682-9377  
 10 rooms at special rates (good through May 11) of:  
 One Bed Room - \$53.95 Thursday; \$62.95 Friday & Saturday.  
 Two Bed Room - \$80.95 Thursday; \$89.95 Friday & Saturday.

### My wife likes all the car-related activities planned, but what will I do?

- . Visit the Northern Great Lakes Visitor Center, [www.NGVC.org](http://www.NGVC.org)
- . Visit the Ashland Historical Museum, 715-682-4911
- . Visit the Washburn Historical Museum, 715-373-5591
- . Visit the Big Top Chautauqua, [www.bigtop.org](http://www.bigtop.org)
- . Take the ferry to Madeline Island, [www.madferry.com](http://www.madferry.com)
- . Rent a moped on Madeline Island, [www.madelineisland.com](http://www.madelineisland.com)
- . Visit the Madeline Island Historical Museum, 715-747-2415
- . Cruise & explore the Apostle Islands, [www.apostleislands.com](http://www.apostleislands.com)
- . Visit, shop & dine in Bayfield, [www.bayfield.org](http://www.bayfield.org)
- . Visit the Bayfield Heritage Museum, 715-779-3272
- . Rent a kayak & explore Lake Superior from shops in Bayfield
- . Visit Cornucopia, [www.cornucopiawisconsin.org](http://www.cornucopiawisconsin.org)
- . Visit the Oulu Glass Studio, [www.ouluerglass.com](http://www.ouluerglass.com)
- . Gamble at Islevista Casino, [www.redcliff.org](http://www.redcliff.org)
- . Play 18 holes of golf (A Rendezvous Golf coordinator will contact you if register to do so)





# Rally in the Valley 2009

August 6<sup>th</sup> thru 9<sup>th</sup> (2009)

**What is the definition of "Rally"?**

**(A gathering of people intended to arouse enthusiasm!)**

**"Rally in the Valley" is a European InterMarque sports car event.**

Sponsored by: The Minnesota MG Group.

Hosted by: Steve and Diane Rindt

**2009 Theme, "Those Were The Days"**

**All New Location:**

The Eau Claire Travel and Business Center  
Sleep Inn and Suites / 29 Pines  
5872 33rd Ave - Eau Claire, WI 54703

**Beautiful Wisconsin Roads for the scenic drives:**

These Rallies are not for the serious rallier. They are fun with easy directions & questions, "spouse friendly"



**Schedule:**

- Thursday (6<sup>th</sup>)– Registration & Natter – N – Noggin.
- Friday (7<sup>th</sup>) – Magic Carpet Ride Rally.
- Friday Evening (7<sup>th</sup>) – Italian Banquet & Live music.
- Saturday (8<sup>th</sup>) - Country Tour, Car Show & Funkhanna.
- Saturday Evening (8<sup>th</sup>) - Awards Dinner/Ceremony.
- Sunday (9<sup>th</sup>)- Farewell breakfast.

For questions please contact Diane Rindt (715) 832-8316 or email [drindt5953@hotmail.com](mailto:drindt5953@hotmail.com)

**Make your reservations at: Sleep Inn & Suites Conference Center / (715) 874-2900.  
Ask for the "Rally in the Valley 2009" special rate. (\$79.99 a night for 2 Queen or 1 King)**

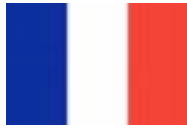

# Rally in the Valley 2009

August 6th, 7th and 8th at Sleep Inn & Suites - Eau Claire, WI

<b>Name:</b>			
<b>Address:</b>			
<b>Email:</b>			
<b>Vehicle/s to Register:</b>	<b>Year:</b>	<b>Make:</b>	<b>Model:</b>
	<b>Year:</b>	<b>Make:</b>	<b>Model:</b>
<b>Friday &amp; Saturday Breakfast Buffet:</b> (Cost includes BOTH days.) Cost includes tip and tax.			
Adult (\$15.00) x Qty		= Total	
<b>Friday Lunch:</b> (Magic Carpet Ride Rally) Cost includes tip and tax.			
Adult (\$11.00) x Qty		= Total	
<b>Friday Night:</b> (Italian Banquet) Cost includes tip and tax.			
Adult (\$18.00) x Qty		= Total	
<b>Saturday Night:</b> ("Those Were The Days" Awards Banquet) Cost includes tip and tax.			
Adult (\$26.00) x Qty		= Total	
<b>Rally in the Valley T-Shirts:</b> ("Those Were The Days")		(Circle Size)	
Men's (\$15.00) x Qty	= Total	Size: S, M, L, XL, (2XL add \$2.00)	
<b>Rally in the Valley T-Shirts:</b> ("Those Were The Days")		(Circle Size)	
Women's (\$15.00) x Qty	= Total	Size: S, M, L, XL, (2XL add \$2.00)	
<b>Rally in the Valley Registration Fee:</b>			
(Before June 30, 2009) \$40.00 per / couple Total			
(After June 30 <sup>th</sup> ) \$45.00 per / couple Total			
<b>EVENT TOTAL</b>			
Make Check Payable to Diane Rindt.			
Send check & Registration Form to:			
Rally in the Valley - 4271 North Shore Drive, Eau Claire, WI 54703			
(Register Before June 30, 2009) Confirmation of registration will be through your email address only.			
***No refunds after July 12, 2009.***			

Rally in the Valley 2009 – August 6<sup>th</sup> thru 9<sup>th</sup> – Eau Claire, Wisconsin

Make your reservations at: Sleep Inn & Suites Conference Center / (715) 874-2900.  
5872 33rd Ave - Eau Claire, WI 54703

Ask for "Rally in the Valley 2009" special rate. (\$79.99 a night for 2 Queen or 1 King)

For questions, contact Diane Rindt at (715-832-8316) or [drindt5953@hotmail.com](mailto:drindt5953@hotmail.com)



Car show and Swap meet

August 15th 2009

The Minnesota MG Group presents:  
The annual Brit Feszt  
All British Car, Bike Show & Swap-meet at Ellingson's Car Museum 20950 Rogers Dr. Rogers MN 55374

9:00am to 1:00pm  
Peoples choice balloting from 9:00 to 12:00.  
Trophies at 1:00



The Car show is

Free to the Public  
Tour the museum for \$5.00



Show your vehicle for \$5

Swap meet spaces

\$10 per space

Please no FOR SALE signs on any vehicles.

The areas largest  
**All British** Car & Bike Show and swap meet! Now in our 12th year!



Ellingson's Car Museum  
20950 Rogers Dr.  
Rogers, MN 55374-9191  
Corner of Hwy 101 and I-94 in Rogers  
Contact: Minnesota MG Group,  
Jim Pennoyer (763)536-5472





### MINNESOTA MG REGALIA

Shirts in **various styles** and **colors** with custom-embroidered Minnesota MG Logos are now available for ordering. Items can be picked up at the next Event or shipped directly to the address you specify. A

Shipping & Handling fee of \$5.00 will be added.

Add an additional fee of \$3.00 if you want your name stitched on your purchase.

To place orders contact: Cindy O'Brien [randycindyo@earthlink.net](mailto:randycindyo@earthlink.net)



MG Girl Tank Top  
\$12.50 each



MG Girl Patches  
\$7.00 each



MMGG Tank Tops  
\$12.50 each



MMGG Sweatshirts  
\$27.00 each



MMGG POLO SHIRTS  
\$24.00 each



MMGG Denim Shirts (Short and Long Sleeve)  
\$30.00 each



\$35.00 each



Short Sleeve T-Shirts  
\$15.00 each



MG Patches  
\$7.00 each

**There are many more options of clothing not shown here when ordering MMGG Regalia. Ask Cindy if you want to see the various styles of:**

**Jackets (Summer/Fall and Winter) - Hats (Base Ball, Stocking Caps, Visors) - T-Shirts Short/Long Sleeve, Tank Tops - Denim, Polo, Dress Shirts - Sweat Shirts Plain/Hooded, Pullover/Zipper**



# Business Ads



**Jeff Schlemmer**  
jeff@advanceddistributors.com

*Rebuild and Recurve Specialists*

612-804-5543  
1149 Quincy Street  
Shakopee, MN 55379  
www.advanceddistributors.com



**MIDWEST MOTOR SPORTS, INC.**

728 8<sup>th</sup> Avenue South  
Sauk Rapids, MN 56379  
**(320) 251-0676**  
SPORTS CAR SPECIALISTS  
www.sportscarguys.com

**BMC British Automobile**  
BMCAutos.com

6810 225th Ave NE, Stacy, MN 55079

- Full Restorations, Drivers to Concourse
- Repair and Maintenance
- Vehicle Alterations and Upgrades
- Motor and Driveline Conversions
- Online Conversion Store

Proprietor: Brian McCullough  
651-462-0145 Brian@BMCAutos.com

**Quality Coaches, Inc.**  
20 West 38th St. (38th & Nicollet)  
Minneapolis, MN. 55409  
Ph. 612-824-4155, Fax 612-824-4460 Email:  
[ValW@quality-coaches.com](mailto:ValW@quality-coaches.com)

**MOSS Distributor**  
STOCKING PARTS TO KEEP YOUR MG-  
TRIUMPH-AUSTIN HEALY RUNNING.  
**30 YEARS SERVICE FOR BRITISH CARS,  
FOREIGN & DOMESTIC REPAIR.**



*Eau Claire British Car*

Quality service and restoration  
715-456-1174  
www.eauclairebritishcar.com  
British and Foreign Classic Cars  
Steve Rindt  
4271 North Shore Drive, Eau Claire WI 54703



**CARS WANTED**

Very Serious Buyer for:  
Jaguar, XK-XKE, MG-"T" series, MGA  
Triumph, TR-2-3-4-250  
Mercedes 190-220-230-250-280 SL  
All open cars Porsche 356-911-914  
Austin Healey, Riley, Alfa-Romeo, Singer  
1964-1967 Ford Mustang, Model T, A

Entire Collections Possible  
ANY CONDITION-ANY LOCATION  
Generous Finder's Fee. WILL PAY THE MOST !

1930's-1960's  
Buying Restored Gas Pumps  
Also other interesting cars  
European and American made

STEVE'S BRITISH CONNECTION USA  
(630) 553-9023 email [sbcinc@aol.com](mailto:sbcinc@aol.com)



**Jeffrey**  
**BODY SHOP**

**COLORMAN / BRITISH AUTO**  
4108 20th Ave South Mpls, MN.55407  
JeffJamesPaint@Yahoo.com 612-724-5267



---

### For Sale or Wanted & Miscellaneous

Minnesota MG Group members' ads will run free for three months, unless you tell the editor to drop them earlier or run them longer. The month/year the ad was placed is in italics below the ad. Commercial Ads as follows: Business Card—\$10.00/issue; 1/4 page—\$20.00/issue; 1/2 page—\$30.00/issue; full page—N/A. All commercial ads must run a minimum of 6 months and must be paid in advance. Send to Ruth Marston, 1920 Roselawn Ave W, Falcon Heights, MN 55113 or [remarston@comcast.net](mailto:remarston@comcast.net). Make checks payable to the MMGG. If you are a member, please indicate this when placing the ad or notice and provide a full name so information can be verified.

---

**For Sale: 1977 MGB Roadster** - 51,773 actual miles-manual and full history - \$4,300.00-call Bill McReaken (952) 890-0102 (Jun 09)

**For Sale: MGBGT** Driver's side quarter panel, NOS. Call Todd Wyatt (320) 980-2010 (*Mar 09*)

**For Sale: 1969 MGB GT** - complete driveline for sale. Coming from a partial restoration and V6 driveline conversion. Nice running engine, good set of HS4 carbs, completely restored MGB Overdrive. The system as is will come with the carbs, starter, alternator, motor, distributor, Overdrive gearbox and driveshaft - will consider splitting. Maintenance records available. Installation into your MGB available if desired. Also available is an MGB 3 main short block that was partially rebuilt and stored a number of years ago. Please email: [brian@bmcautos.com](mailto:brian@bmcautos.com) or telephone 651.462.0145. (March 09)

**For Sale: 2002 MINI Cooper** - 43,800 miles Red with Black roof and slate black interior. Every option, including Navigation system, leather interior, cold weather package (heated washer fluid, heated seats, heated mirrors), sunroof, stability control, 16" wheels, fog lights, xenon headlights, sport suspension, aero package ground effects. Has extra bumper set front and rear, fitted MINI car cover & much more. Always stored in winter in heated garage. New tires. Always properly maintained. If you're thinking of getting a MINI-this is the car to buy - \$12,000.00 firm. Contact Dick Wallrich for info on add'l options. 651-644-0154. (May 09)

#### New and Refurbished MGB Parts For Sale:

**MGB Windshield** - MGB Roadster windshield with new chrome plating on the frame, new Moss Triplex tinted glass and new seals. All assembled - \$950.00

**MGB Windshield** - MGB Roadster windshield with refurbished frame with new Moss tinted glass and new seals. All assembled - \$480.00

**MGB Windshield Frame** - MGB Roadster windshield frame-refurbished and assembled to confirm proper fit - \$210.00

**MG Midget Windshield Frame** - MG Midget windshield frame with **New Chrome Plating** and new post retainers - \$550.00

**MGB-GT Windshield Wiper Arms** - Black - \$ 20.00 ea.

**MGB Wood Veneer Trim Set** - center console and glove box door - MGB '72-'76 - Cherry or Walnut Wood - \$110.00, Ash or Oak Wood \$95.00

**MGB Seat Set** - Professionally installed new custom upholstery over refurbished frames, new foam and new seat webbing - plus new Teardrop style head rests. Black with Red piping. Complete and ready for installation - \$1125.00

**MGB Seat Set** - Professionally installed upholstery over refurbished frames and new foam and seat webbing. With "D" style head rests. Complete and ready for installation. Autumn Leaf color vinyl - \$685.00

**MGB Dash** - Refurbished dash for '72-'76 MGB. New total dash face installed over a completely refurbished dash base. Ready to install - \$445.00

**MG 14" Wheels** - Original Rostyle MG wheels. Refurbished and restored to original color and then clear coated. Set of 5 - \$400.00

**MGB Rear Bumper** - New rear bumper, '70-'74 MGB style, complete with all new brackets and new over riders/bumper guards - \$200.00

**MGB Brake Pipe Set** - New copper-nickel set for '68- early '74 MGB - \$ 65.00

**Engine Hoist** - 2 ton folding engine hoist - including an engine leveler - \$ 95.00

*Please Contact Roger Olson at 763-420-8159 or cell 612-963-1127 - [www.rljolson@embarqmail.com](mailto:www.rljolson@embarqmail.com).*

---

### *Quality Coaches, Inc.*

Call Mark @ Quality Coach Inc. on his cell phone at 612-306-0044

1952 MGTD. Stored for 10 years, new brakes, runs, needs carb & fuel system work. \$7995

1960 Austin Healey 3000 MK I BT7. Red with black interior, chrome wire wheels, tonneau, older soft top. Has overdrive. \$20,000 invested in recent restoration, selling for only \$30,000

1962 Midget, MK I Green. Mag wheels with a 1275 engine, 5 speed trans. This is a distressed sale. \$5,500

1979 MGB White with wire wheels. Needs a new owner soon. \$4,895

1979 MGB Orange with black interior. Rose style wheels. 85k miles. \$5,500 OBO

---

MMGG will not sell your information or share it with third parties for marketing or other purposes.

The MMGG *Gazette* welcomes all articles, features and letters. Please submit as text documents. All articles, features and letters will be subject to editing but all efforts will be made not to change the meaning of the submitted document. Please submit articles for publication in the *Gazette* by the 15th of the month to [minnesotamggroup@me.com](mailto:minnesotamggroup@me.com) or [remarston@comcast.net](mailto:remarston@comcast.net)

---



**Minnesota MG Group Membership Form**

*The Minnesota MG Group was founded in 1987 and is dedicated to the preservation, restoration, maintenance and enjoyment of all MG cars. MG car ownership is not necessary to be a member of the Minnesota MG Group.*

Membership is \$35.00 with a \$5.00 discount if paid before the spring Kick Off Brunch - March 28, 2009. The membership year runs from January 1st to December 31st. New members joining after August 31st of any given year shall be granted membership for the remainder of that year and the next year as well.

Use this form to join, renew or change your membership. Please complete this form and include a check for \$35 (or \$30 if paying before mid-March).

**MMGG will not sell your information or share it with third parties for marketing or other purposes.**

**Mail to:** Minnesota MG Group c/o Diane Vinar, 275 Tiffany Drive, Hastings, MN 55033 [dmvinar@yahoo.com](mailto:dmvinar@yahoo.com)

New    Renewal    Changes    (Circle one)

Name \_\_\_\_\_ Spouse/partner/significant other \_\_\_\_\_

Street Address \_\_\_\_\_ City, State, & Zip \_\_\_\_\_

Telephone w/area code (\_\_\_\_\_) \_\_\_\_\_ - \_\_\_\_\_ Email Address \_\_\_\_\_

MG's Owned \_\_\_\_\_

Minnesota MG Group  
c/o Diane Vinar  
275 Tiffany Drive  
Hastings, MN 55033

